

Fast and Safe Change



König Quick-Change Chucks

Reduced tooling expenditure and set-up costs
at high machining accuracy via easier and
faster change of clamping mandrels or chucks



More Productivity for your Machine Tools

Experience in clamping technology

For decades, König-mtm has been one of the leading manufacturers of state-of-the-art high-precision clamping devices. The extensive production program covers clamping tools such as mandrels and chucks in hydraulic or mechanical versions.

Clamping tools for market leaders

König-mtm's clamping chucks and the Königdorn® are well known in the tool industry and are well established as original equipment on top-class high-precision CNC controlled machine tools.

The König quick-change chuck

For today's machine tools the complexity of machining tasks, the variety of workpieces and accordingly the number of clamping tools increase permanently.

Resulting from substantial experience in clamping technology König-mtm has developed a new generation of quick-change chucks. These chucks minimize tooling expense as well as changeover times. This yields reduced costs and higher productivity, meeting the basic requirement of more efficient machining operations.

Better workpiece flexibility

Machine tools equipped with König-mtm's quick-change chucks allow faster change of clamping tools versus machines with conventional chucks.

Accordingly, as lot sizes decrease the number of machine tools operating in frequent change-over environments is increasing.



The hydraulic König Quick-Change Chuck



One connection for all clamping tools

By harmonizing the adaption configuration, a simple effortless change of the clamping device is possible.

Easy and safe operation

The quick-change chuck is operated manually by a hexagonal key. By means of the pressure being built up within the clamping sleeve, the mandrel or chuck is centered, clamped and axially located against the flange with positive force. This results in solid full-contact clamping which assures an absolutely deflection-resistant connection between quick-change chuck and workpiece clamping tool.

Operation of clamping tools as usual

Usually, the clamping mandrels and chucks are operated directly by the hydraulic system of the machine or by a pressure transmitter which is integrated in the quick-change chuck.

On relaxing, integrated springs push the piston back to the starting position.

Technological advantages

- Easy changeover of the clamping tools (no screws – no bolt on)
- Good radial and axial run-out accuracy
- Excellent wear-resistance

Economic advantages

- Reduced effort during set-up changes of tooling
- Reduced retooling times
- Reduction of tooling costs
- High workpiece flexibility
- Increased productivity

Made-to-measure for every machine

The type as well as the specific design of the quick-change chuck is individually tailored to the construction of the machine tool, the machining tasks and the shape of the workpieces.

The design of the König quick-change chuck

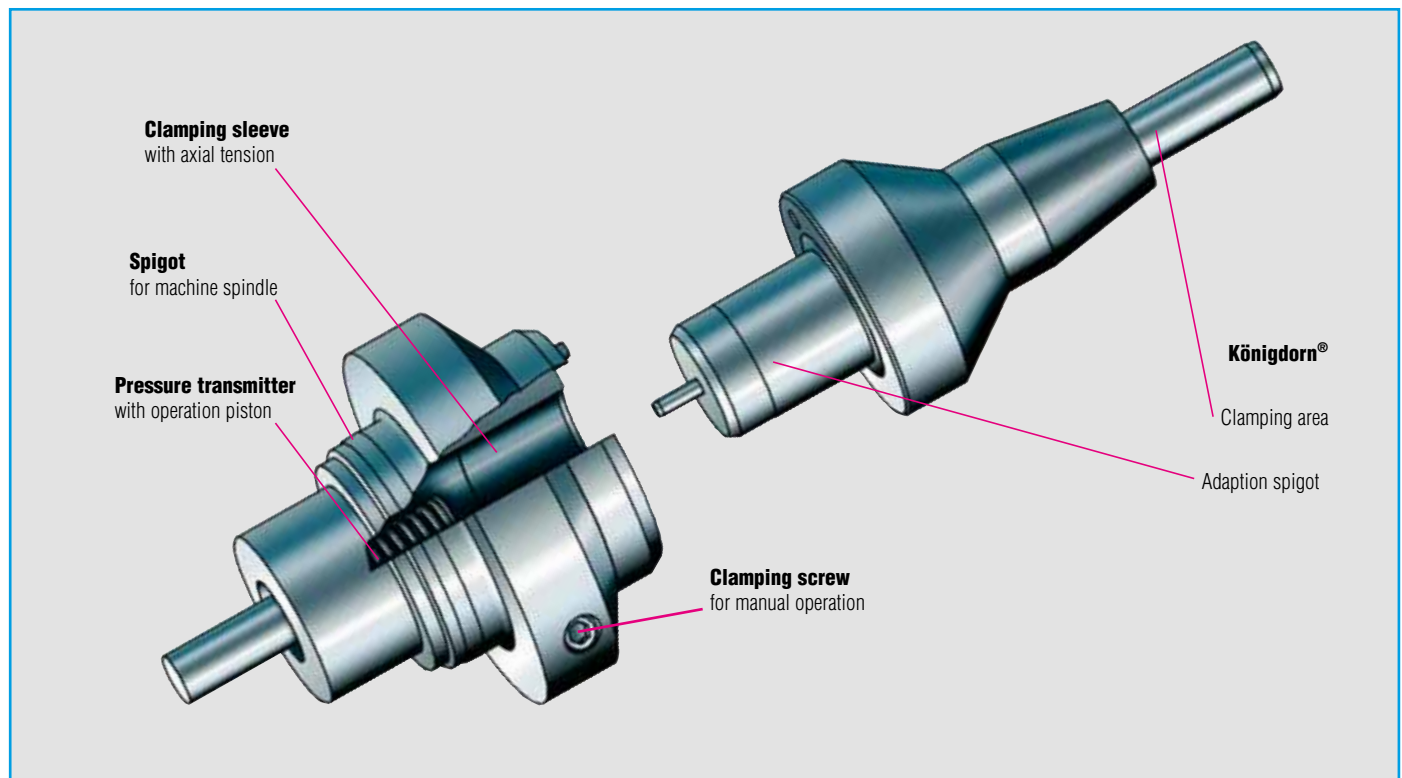



The König Group is located in Wertheim, the most northern town of Baden-Württemberg.

Lying on the confluence of the Main and Tauber rivers, the former seat court of the Count of Wertheim has a particular atmosphere with its ancient lanes, half-timbered houses and the castle ruin from the 12th century.



König-mtm GmbH, Spanntechnik

Postfach 14 63 · D-97864 Wertheim
Am Stammholz 13 · 97877 Wertheim
Tel.: +49 (0) 93 42 8 76-0
Fax: +49 (0) 93 42 8 76-1 23
e-Mail: sales@koenig-mtm.de
www.koenig-mtm.de

Production Program

- Mechanical mandrels
- Hydraulic mandrels
- Mechanical chucks
- Hydraulic chucks
- Splined mandrels
- Light-weight mandrels
- Complete holding devices
- Electronic clamping pressure control
- Special mandrels
- Clamping mandrels for hobs
- Rotor milling devices
- Special collet chucks
- Special flanges
- Spindles

Quality Management:
ISO 9001:2008 certified

Environment Management:
ISO 14001 certified

© 2013 by König-mtm, Spanntechnik

Products and methods are subject to change without notice.